

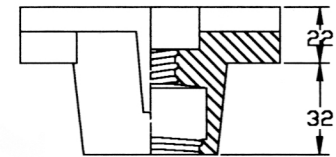

STANDARD TOP ADJUSTMENT EPOXY COATED SERVICE BOX

CSB1

Please note that drawings are approximate and not to be used for engineering purposes – please contact us for specific dimensions.

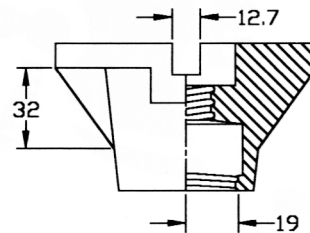
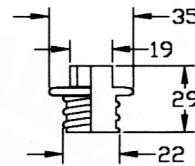
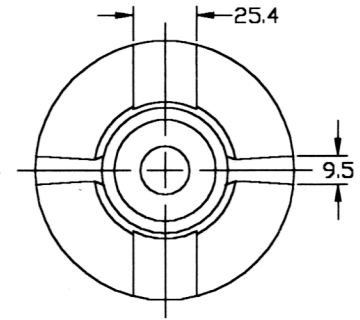
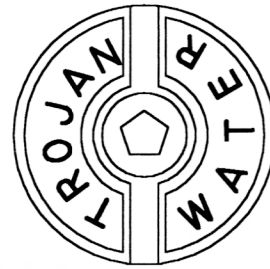
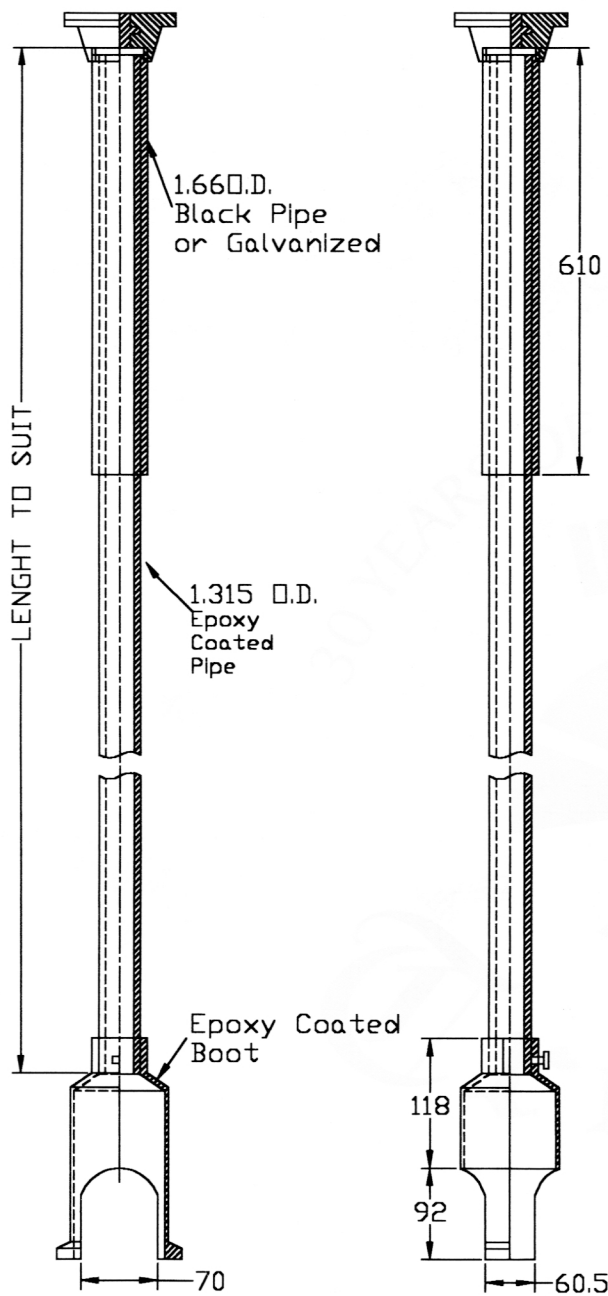

Material:
 1.66 O.D. Upper section 1.315 O.D. Casing-ASTM A-500 Type 1 HRR Steel
 Cast Iron Cap and Boot- ASTM A-48 Class 20 Grey Iron
 Boot Epoxy Coated
 1.315 O.D. Casing Epoxy Coated
 Brass Pentagon Plug - CDA 60-40 Yellow Brass

SMALL BOOT FOR 20mm & 25mm SERVICE

TROJAN INDUSTRIES INC.